

GF 3-2630-X Amperometric Free Chlorine Electrode
GF 3-2632-X Amperometric Chlorine Dioxide Electrode

3-2630.090 Rev 16 02/22

Manual**Description**

The GF Amperometric Chlorine Electrodes is designed for use in fresh, clean water treatment applications where a level of Chlorine is always detectable. Free Chlorine electrodes are available in measurement ranges of 0.02 to 2 ppm, 0.05 to 5 ppm or 0.1 to 20 ppm.

Chlorine Dioxide electrodes are available in measurement ranges of 0.02 to 2 ppm. Electrodes require the 2650 Amperometric Electronics to output a digital (S²L) signal to the 9950-X Chlorine Controller.

Features:

- Utilizing smart-sensor technology, this electrode incorporates a unique embedded memory chip within the electrode to communicate a wide variety of information to the 2650 Amperometric Electronics and 9950-X Chlorine Controller. Electrode type, factory calibration data, service time, chlorine range, high and low temperature and more are stored on the chip. This information is accessible via the 9950-X Chlorine Controller.
- GF's patented DryLoc[®] connector provides quick assembly and a secure connection. Gold-plated contacts and an O-ring seal ensure a waterproof and reliable interconnect to the 2650 Amperometric Electronics.
- Integrated temperature element for automatic temperature compensation.
- Separate drive electronics (2650) allow easy electrode replacement without running new cable.

* NOTE: The 9950-X Chlorine Controller is not compatible with the standard 9950 controller.

**CAUTION!**

1. Follow instructions carefully to avoid personal injury or damage to electrode.
2. Prior to installation or removal:
 - a. Disconnect flow through system.
 - b. Drain below sensor level.
3. Confirm chemical compatibility before use.
4. Do not exceed the maximum pressure or temperature specifications.
5. Do not alter product construction.

WARNING: The GF Chlorine Analyzer (electrode) is designed to be used in a clean, chlorinated flowing stream at all times. **DO NOT** use in applications where electrode could be exposed to periods without chlorine.



- [English](#)
- [Deutsch](#)
- [Français](#)
- [Español](#)
- [Italiano](#)
- [中文](#)



Warranty Information

Refer to your local Georg Fischer Sales office for the most current warranty statement.

All warranty and non-warranty repairs being returned must include a fully completed Service Form and goods must be returned to your local GF Sales office or distributor. Product returned without a Service Form may not be warranty replaced or repaired.

GF products with limited shelf-life (e.g. pH, ORP, chlorine electrodes, calibration solutions; e.g. pH buffers, turbidity standards or other solutions) are warranted out of box but not warranted against any damage, due to process or application failures (e.g. high temperature, chemical poisoning, dry-out) or mishandling (e.g. broken glass, damaged membrane, freezing and/or extreme temperatures).

Safety Information









	Caution / Warning / Danger Indicates a potential hazard. Failure to follow all warnings may lead to equipment damage, injury, or death.
	Electrocution Danger Alerts user to risk of potential of injury or death via electrocution.
	Electrostatic Discharge (ESD) Alerts user to risk of potential damage to product by ESD.
	Personal Protective Equipment (PPE) Always utilize the most appropriate PPE during installation and service of GF products.
	Pressurized System Warning Sensor may be under pressure, take caution to vent system prior to installation or removal. Failure to do so may result in equipment damage and/or serious injury.
	Hand Tighten Only Overtightening may permanently damage product threads and lead to failure of the retaining nut.
	Do Not Use Tools Use of tool(s) may damage product beyond repair and potentially void product warranty.
	Note / Technical Notes Highlights additional information or detailed procedure.
	Do Not Freeze Products are temperature sensitive and may contain freezable liquids. Freezing damage to pH, ORP, and Chlorine electrodes voids product warranty.

Table of Contents

Description	1
Warranty Information.....	2
Safety Information.....	2
Dimensions	2
Specifications	3
Sensor Preparation	4
Operation	5
Calibration	5
Maintenance.....	6
Storage	7
Reconditioning	8
Installation	9
Mounting Position	9
Overview	10
Troubleshooting	11
Ordering Information.....	12

Dimensions

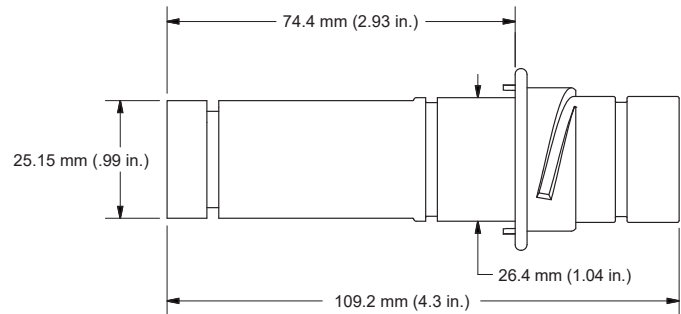

Specifications

General

Polarization SourceGF 2650 Amperometric Electronics
Compatible Flow
CellsGF 3-3610-1 (159 001 683)
GF 3-3610-2 (159 001 684)
GF 3-4630.392 (159 001 690)
MountingGF DryLoc connection
MaterialsCPVC
MembranePTFE
O-ringFKM
Working electrodeGold
Counter reference
electrodeSilver halide

Wetted MaterialsPVC, PTFE, FKM, Nylon, Silicone

Performance Specifications

Electrode
Repeatability±0.08 ppm (mg/L) or 3% of selected
range, whichever is less
Free Chlorine Slope ...15 to 60 nA/ppm (mg/L) @ 25 °C
Chlorine Dioxide
Slope40 to 200 nA/ppm (mg/L) @ 17 °C
Response Time, T90 ..< 2 minutes

System (including electronics and instrument)
Accuracy<±3% of electrode signal after
calibration
Resolution<0.5% of electrode range

Sensor Conditioning
New, first start up4 hours maximum before calibration
Subsequent
start ups2 hours maximum

Temperature
Element Pt1000

Operational Ranges and Limits

Free Chlorine
Range
3-2630-10.02 to 2 ppm (mg/L)
3-2630-20.05 to 5 ppm (mg/L)
3-2630-30.1 to 20 ppm (mg/L)
pH Operating Range5.5 pH to 8.2 pH

Chlorine Dioxide
Range
3-2632-10.02 to 2 ppm (mg/L)
pH Operating Range4.0 pH to 11 pH

Maximum Operating
Temperature5 °C to 45 °C (41 °F to 113 °F)

Maximum Operating
Pressure0.48 bar @ 25 °C (7 psi @ 77 °F)

Flow Velocity Across Membrane Surface
Minimum15 cm/s (0.49 ft/s)
Maximum30 cm/s (0.98 ft/s)

Sensitivity
Free Chlorine
Cross SensitivityChlorine Dioxide, ozone, bromine
Chlorine Dioxide
Cross SensitivityFree Chlorine, ozone

Chemical Compatibility< 50% ethanol/water
.....< 50% glycerol/water

Environmental Requirements

Storage Temperature
(Dry)-10 °C to 60 °C (14 °F to 140 °F)
System Temperature-10 °C to 60 °C (14 °F to 140 °F)
Relative Humidity0 to 95% indoor/outdoor
non-condensing to rated ambient

Standards and Approvals

- CE, WEEE
- RoHS Compliant
- Manufactured under ISO 9001 for quality
-  China RoHS (Go to www.gfsignet.com for details)

Declaration of Conformity according to FCC Part 15

This device complies with Part 15 of the FCC rules.
Operation is subject to the following two conditions:
(1) This device may not cause harmful interference, and
(2) This device must accept any interference received,
including interference that may cause undesired operation.

Sensor Preparation

- Chlorine sensors are shipped without internal electrolyte solution.
- Prior to installation and supplying power, Chlorine sensors must be filled with the appropriate internal electrolyte solution.
- Verify the correct electrolyte solution is utilized with the corresponding sensor.
- Free Chlorine and Chlorine Dioxide sensors require different electrolyte solutions.



Avoid skin or eye contact with electrolyte solution.

Wear rubber gloves and goggles.

*Safety Data Sheets (SDS) are available online at www.gfps.com.

CAUTION! DO NOT touch the gold tip or the membrane of the sensor.

Initial Fill Procedure:

When adding electrolyte, be prepared for an accidental spill.

Working near a sink is recommended.

1. Remove the protective bottle from the end of the electrode.
2. Remove the membrane cap from the front of the sensor.
Note: When new sensors are shipped, the membrane cap is not tightened to the sensor.
3. Fill supplied syringe with electrolyte solution.
4. Place the electrode on a level surface.
5. Insert syringe needle fully into one of the eight electrode holes while injecting with electrolyte solution. Slowly injecting the electrolyte solution into the sensor to avoid introducing air bubbles. The electrode holds approximately 14 milliliters of solution. Slowly fill until solution begins to flow out of holes. Do not allow the solution to run down the electrode and wet the electrical contacts in the DryLoc connector.
6. Slowly screw on the membrane cap finger tight. Do not use tools.
To avoid damage and contamination, do not touch the white membrane surface on the membrane cap.



Operation

Electrode Range: The electrode must match the type and range of chlorine concentration to be measured.

Flow Rate:

The electrode must have a stable and constant flow of water past its membrane for accurate measurement. When the sensor is installed in the Tee flow cell (see Ordering Information), the flow rate must range from 37.8 to 75.7 LPH (10 to 20 US g/h).

When the sensor is installed in the Flow Cell Block 3-4630.392 (159 001 690), the flow rate range should be 30.24 to 45.36 LPH (8 to 12 US gph).

Sensor Conditioning: 4 hours

A new electrode requires conditioning of 4 hours with the electrode powered on and chlorinated water flowing past the sensor tip to generate a stable reading.

Subsequent start-ups can require an electrode conditioning of up to two hours.

Part Number	Chlorine Range	Chlorine Type
3-2630-1	0.02 to 2 ppm (mg/L)	Free Chlorine
3-2630-2	0.05 to 5 ppm (mg/L)	
3-2630-3	0.1 to 20 ppm (mg/L)	
3-2632-1	0.02 to 2 ppm (mg/L)	Chlorine Dioxide



The electrode should not be used in water containing surfactants, oils, organic chlorine or stabilizers such as cyanuric acid.



The maximum allowable operating pressure must be less than 0.48 bar (7 psi). Higher pressures will damage the electrode.

Calibration

A new chlorine electrode or one that has had the membrane cap changed must be calibrated. Refer to the 463X Analyzer System or 9950-X Chlorine Controller manuals for electrode and instrument calibration information. A diethyl-p-phenylenediamine (DPD) colorimeter test kit (not included) is required for sensor calibration. A sample is taken and analyzed with the DPD test kit, then this value is entered into the GF 9950-X Chlorine Controller.

- Calibrate after a membrane cap change.
- Check calibration one day after sensor is placed in service.
- Check calibration weekly to monthly depending on process requirements.

Maintenance

Verifying the sensor's accuracy using the DPD method should be performed to determine if the sensor requires maintenance.

1. Inspect the membrane for dirt or damage. Replace the membrane if it's torn or if the gold cathode is visible.
2. If the membrane is dirty clean the membrane by soaking it in 1 - 5% HCL and gently wash with a stream of DI water. (do not use any mechanical device on the membrane)



**Diluted HCl can irritate the eyes and skin, use proper safety equipment.
Do not use surface tension reducing chemicals, detergents or solvents on the membrane.**

If a fresh water rinse does not clean the membrane, it will need to be replaced.
Keep spare membrane caps available. Membrane caps carry no warranty.



**Avoid skin or eye contact with electrolyte solution.
Wear rubber gloves and goggles.**
*Safety Data Sheets (SDS) are available online at www.gfps.com.

Additional caution should be taken when handling the Chlorine Dioxide electrolyte solution.

Refill Procedure:

When adding electrolyte, be prepared for an accidental spill.
Working near a sink is recommended.

1. Remove the membrane cap from the front of the sensor.
2. Turn the sensor upside down and shake the sensor vigorously to remove the internal electrolyte.
3. Fill supplied syringe with electrolyte solution.
4. Place the electrode on a level surface.
5. Insert syringe needle fully into one of the eight electrode holes while injecting with electrolyte solution. Slowly injecting the electrolyte solution into the sensor to avoid introducing air bubbles. The electrode holds approximately 14 milliliters of solution. Slowly fill until solution begins to flow out of holes. Do not allow the solution to run down the electrode and wet the electrical contacts in the DryLoc connector.
6. Slowly screw on the membrane cap finger tight. Do not use tools. To avoid damage and contamination, do not touch the white membrane surface on the membrane cap.



Storage



Dry electrodes are shipped and need to be stored between $-10\text{ }^{\circ}\text{C}$ to $60\text{ }^{\circ}\text{C}$ ($14\text{ }^{\circ}\text{F}$ to $140\text{ }^{\circ}\text{F}$) at a relative humidity that does not exceed 95%. The primary concerns when storing the electrode is damage to the membrane.

If the sensor or panel assembly is to be removed from service for a period of time the sensor must be properly prepared for storage and may need to be recommissioned.

Storage periods of 1 week or less:

- Close the drain valve, then close the inlet valve of the flow cell, to maintain water inside the flow cell to keep the membrane wet.
- If draining the flow cell is required, remove the sensor from the cell and the 2650 electronics and store in the shipping bottle with tap water added.

Storage periods more than 1 week:

- Remove the membrane cap and internal electrolyte solution.
- Rinse the sensor internal chamber with DI water or cold tap water; drain and allow to dry.
- Place the membrane cap back onto the sensor. **INSTALL LOOSE, DO NOT COMPLETELY TIGHTEN THE CAP. WHEN STORED DRY, THE MEMBRANE CAP MUST BE STORED RELAXED AND UNSTRESSED.**
- Store sensor DRY in the shipping bottle, **DO NOT ADD WATER.**

Recommissioning Procedure:

1. Fill the sensor with the electrolyte as outlined in Maintenance, see page 6, and install the membrane cap.
2. The sensor will have to be polarized in the flow cell with flowing Chlorinated water before being used.
Note: This may take 30 to 120 minutes before calibration can be performed.
3. If the sensor does not recover after recommission, follow steps 1-10 outlined in Reconditioning on page 8.
4. If the sensor still fails to work properly, continue with steps 11-17.

Reconditioning

Required to recondition a sensor:

- DI Water
- Beaker (any size available)
- Polishing Sheets (Included in sensor maintenance kit)
- Free Chlorine: Chlorine Bleach (13% concentration)
- Chlorine Dioxide: Aqueous Chlorine Dioxide solution

Reconditioning Procedure (Steps 1-10):

1. Remove the sensor from the 2650 electronics.
2. Remove the membrane cap.
3. Place the sensor on a firm, flat surface with gold cathode pointing upward.
4. Apply a small amount of water to the blue (coarse) polishing paper (dull side).
5. Polish the gold electrode by moving the paper in a circular pattern for 30 seconds. DO NOT go back and forth in a single direction. See Figure 1.
6. Rinse the sensor tip with DI water.
7. Apply a small amount of DI water to the white (fine) polishing paper (dull side) and polish the gold electrode by moving the paper in a circular pattern for 30 seconds. DO NOT go back and forth in a single direction. See Figure 1.
8. Rinse the sensor tip with DI water.
9. Top off the sensor with electrolyte and inspect membrane for dirt or damage. Replace if necessary.
10. Insert the sensor into the 2650-7 electronics and apply power.

Reconditioning Procedure (Steps 11-17):

11. Fill beaker with a 12 mm ($\frac{1}{2}$ inch) of the appropriate solution.
12. Position or suspend the sensor 6 mm to 12 mm ($\frac{1}{4}$ in. to $\frac{1}{2}$ in.) above the appropriate solution. DO NOT SUBMERGE THE SENSOR. See Figure 2.
13. Apply power to the system.
14. Monitor the nA of the sensor (press the down arrow three times on the 9950-3 Chlorine Controller). The nA reading should start to rise. Response time and nA reading will depend upon the temperature of the bleach.
15. Once the sensor's nA reading reaches approximately 300-360 nA, allow the sensor to remain in the beaker, suspended over the appropriate solution, for an additional 20 minutes.
 - If sensor does not recover, cover the beaker to avoid air contamination.
 - Contact the factory for assistance (www.gfsignet.com)
16. After 20 minutes, remove the sensor from the beaker and install it into the flow cell and restore flow to the system.
17. Calibrate the sensor after the system has become stable.

The electrode is not recyclable. Dispose of properly according to local, state and federal guidelines.

CAUTION!

Bleach and Chlorine Dioxide solutions are very corrosive and may release dangerous gases if they come in contact with acids.



- Wear proper protective clothing (gloves and eye protection)
- Avoid contact with skin and eyes
- Observe all warnings on safety data sheets
- Avoid spilling bleach and possible contact with acids

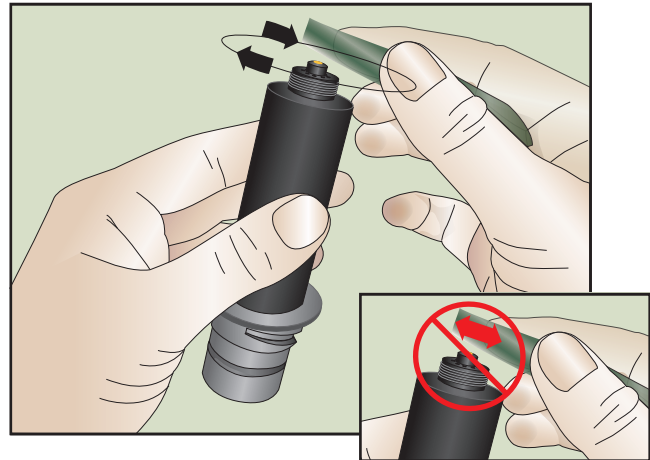

Figure 1

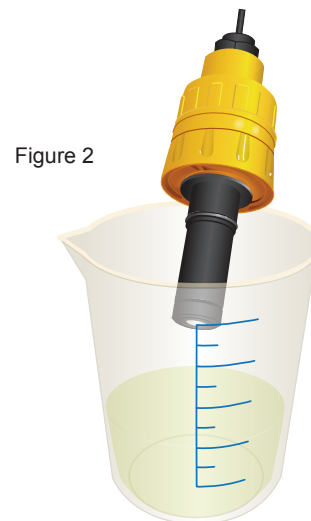
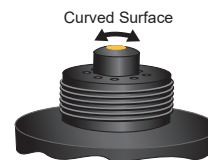
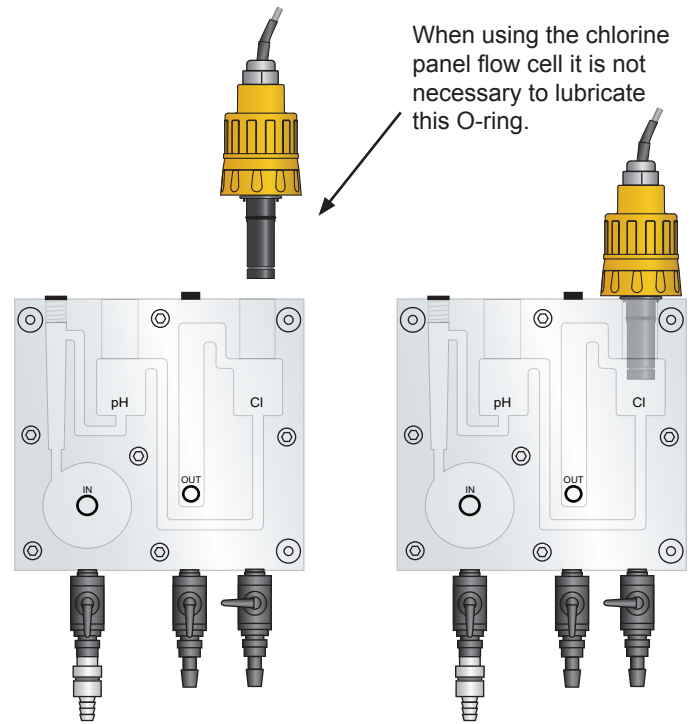
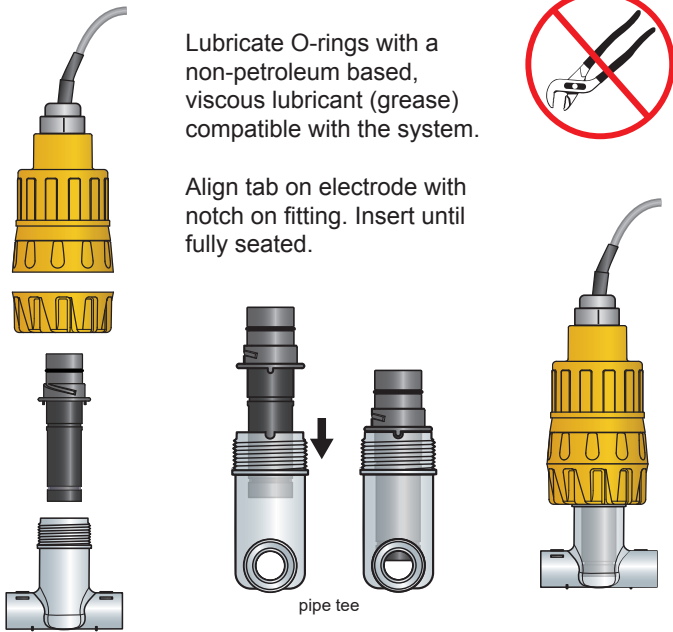

Figure 2

Installation

Do Not Use Lubricant or Sealing Tape on Threads. Do Not Overtighten. Do Not Use Tools.



Mounting Position - PVC Tee

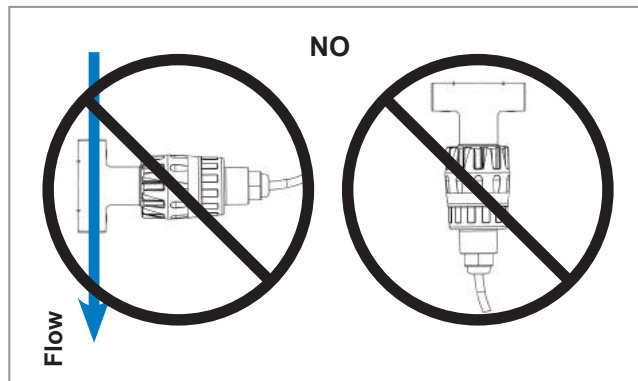
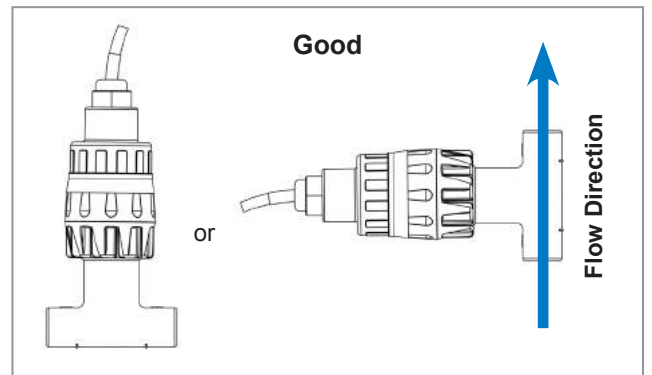
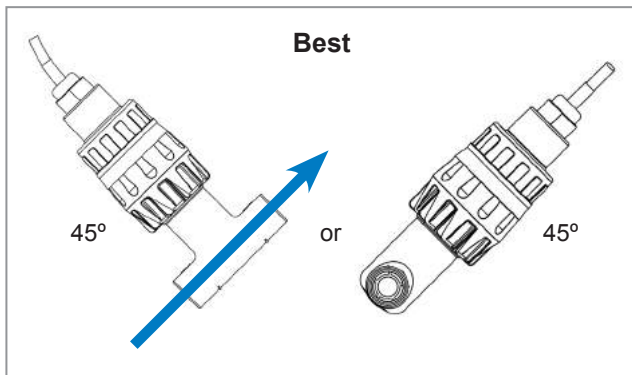

Mount the flow cell where the sensor will be easily accessible. To avoid air bubble entrapment, do not mount with downward flow.

Overview

Chlorine in Water

Various forms of chlorine are used to disinfect water. Each form of chlorine has benefits and limitations which help determine the specific application. The predominant categories used in disinfection are Free Chlorine, Total Chlorine and Chlorine Dioxide. Free Chlorine is the sum of chlorine gas (Cl_2), hypochlorous acid (HOCl) and hypochlorite (OCl^-). Above pH 4.0 all of the molecular chlorine is converted to HOCl and OCl^- . Hypochlorous acid is a more potent disinfectant than hypochlorite and exists in a pH dependent equilibrium as shown in Figure 3.

Free chlorine also combines with naturally occurring or human-introduced nitrogen compounds in the water to form chloramines, also known as combined chlorine. Treatment operators introduce ammonia into the water to form monochloramine (NH_2Cl), dichloramine (NHCl_2) and trichloramine (NCl_3). Chloramines are a less effective disinfectant but have a longer residence time than the free chlorine species. Total chlorine is the sum of free chlorine (Cl_2 , HOCl and OCl^-) and combined chlorine (NH_2Cl , NHCl_2 , NCl_3).

Chlorine Measurement by Amperometric Sensors

GF chlorine sensors are membrane-covered amperometric 2-electrode sensors. A gold or platinum cathode acts as the working electrode with a silver halide acting as the counter electrode. Depending on the species to be analyzed, a polarization voltage is applied between the two electrodes. When placed into service, the chlorine species of interest diffuses across the membrane and is reduced at the cathode surface. For the case of total chlorine, the analyte reacts with the fill solution to produce an intermediate, which is subsequently reduced at the cathode surface. At the same time, the silver anode is oxidized to form a silver halide. The current generated at the cathode is proportional to the rate of diffusion through the membrane and the concentration of chlorine in the sample. The current from the cathode to the anode is conditioned, digitized and transmitted by the associated electronics.

pH Compensation for Free Chlorine

Amperometric free chlorine sensors measure only hypochlorous acid. As noted in the text above and in Figure 3, the ratio of hypochlorous acid and hypochlorite is pH dependent. The GF Free Chlorine Panel assemblies comes complete with a pH electrode to ensure accurate free chlorine measurement if the pH changes.

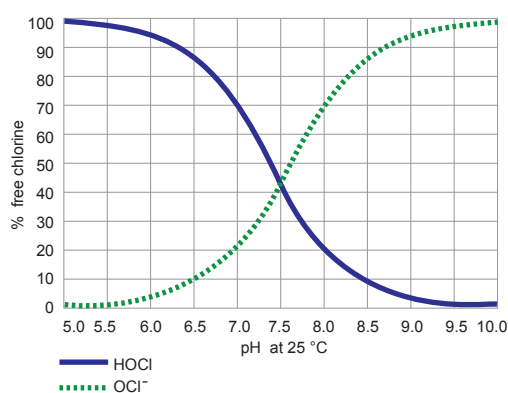

Figure 3

Automatic pH Compensation and Free Chlorine

In many applications, the process pH does not significantly fluctuate and only a chlorine sensor and instrument are necessary for accurate chlorine measurement.

When the pH varies the free chlorine concentration cannot accurately determined without the use of automatic pH compensation.

The addition of the 3-2724-00 (159 001 545) pH electrode along with its 3-2751-7 (159 001 957) sensor electronics to the system makes pH compensation extremely easy and automatic even with wide fluctuations or high pH.

See Figure 4 for pH variation recommendations.

Chlorine dioxide is not pH dependant and does not require a pH electrode or electronics.

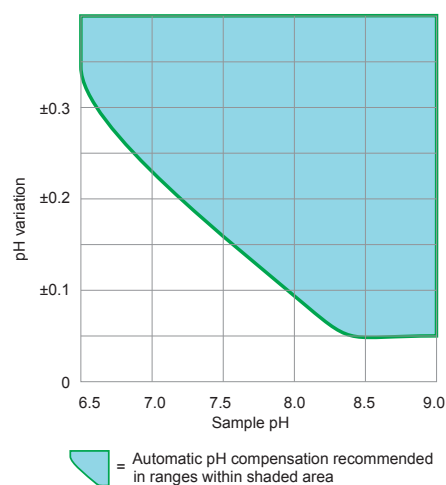

Figure 4

Troubleshooting

Transmitter error messages related to calibration are detailed in the 9950-X Chlorine Controller operation manual.

Problem	Possible Causes	Remedies
Sensor cannot be calibrated. Output is higher than DPD test (out of range).	Sensor conditioning time too short	Condition for 4 hours minimum prior to initial calibration
	Interference from contaminants	See Specifications on page 3
	Membrane cap damaged	Replace cap and recondition
	DPD chemicals bad	Use fresh reagents
	pH outside of working range	See Specifications on page 3
Sensor cannot be calibrated. Output is lower than DPD test.	Sensor conditioning time too short	Condition for 4 hours minimum prior to initial calibration
	Chlorine content too low	DPD value must be greater than 0.5 ppm to calibrate
	Low flow rate	Check to make sure flow rate is sufficient
	Air bubbles on electrode membrane	Inspect visually. Tap to remove bubbles. Mount at an angle.
	Low or no electrolyte in electrode	Fill electrode with electrolyte
	Organic chlorination agents present in water	See technical data
	Surfactants in water	Remove surfactants and replace cap
	Membrane cap coated	Clean or replace membrane cap
	Membrane cap loose	Tighten or replace membrane cap
	pH outside working range.	See Specifications on page 3
Sensor output very low	Sensor conditioning time too short	Condition for 4 hours minimum prior to initial calibration
	Chlorine content too low	Add chlorine to validate
	Only bound chlorine present. No free chlorine	Check for chloramine with appropriate DPD test
	Electrode not making good contact with electronics	Inspect and reconnect
Unstable output from sensor	Air bubbles on electrode membrane	Inspect visually. Tap to remove bubbles. Mount at an angle.
	Membrane damaged	Replace membrane. Condition sensor for at least 2 hours and recalibrate.
	Electrode not making good contact with electronics	Inspect and reconnect
	Non-sensor problem	Check 3-2650 Electronics connection to electrode (see 3-2650 manual for instructions). Make sure connections are dry. Check instrument hookup.

Ordering Information

Mfr. Part No.	Code	Description
3-2630-1	159 001 746	Free Chlorine electrode, 0.02 to 2 ppm (mg/L)
3-2630-2	159 001 662	Free Chlorine electrode, 0.05 to 5 ppm (mg/L)
3-2630-3	159 001 747	Free Chlorine electrode, 0.1 to 20 ppm (mg/L)
3-2632-1	159 001 767	Chlorine Dioxide electrode, 0.02 to 2 ppm (mg/L)

Accessories and Replacement Parts

Mfr. Part No.	Code	Description
3-2630.391	159 001 674	Free Chlorine electrolyte, 30 mL
3-2632.391	159 310 160	Chlorine Dioxide electrolyte solution, 30 mL
3-2630.394	159 310 164	Free Chlorine and Chlorine Dioxide Replacement PTFE membrane (1)
3-2630.398	159 310 166	Free Chlorine Sensor maintenance kit - (2) electrolyte, (2) PTFE membranes, (2) Silicone Bands, and Polishing Paper
3-2632.398	159 310 165	Chlorine Dioxide maintenance kit - (2) electrolyte, (2) PTFE membranes, (2) Silicone Bands, and Polishing Paper
3-2600.510	159 500 422	Silicone Band, Chlorine electrode
3-3610-1	159 001 683	Flow Cell, Clear PVC 1/2" Tee
3-3610-2	159 001 684	Flow Cell, Clear PVC 1/2" Tee, Barb Conn



Georg Fischer Signet LLC, 5462 N. Irwindale Avenue, Irwindale, CA 91706 U.S.A • Tel. (626) 571-2770 • Fax (626) 573-2057
For Worldwide Sales and Service, visit our website: www.gfps.com • Or call (in the U.S.): (800) 854-4090
For the most up-to-date information, please refer to our website at www.gfps.com